

EX-14

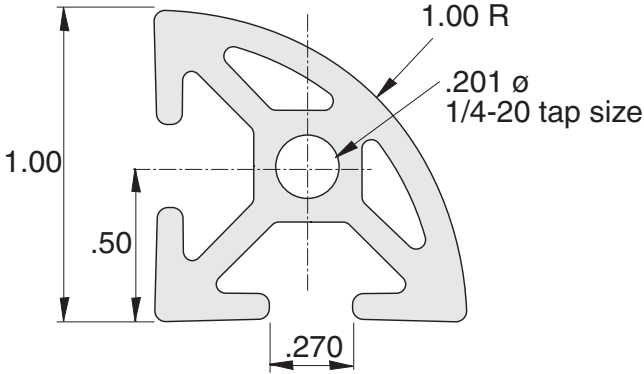

- Finish = Clear anodized
- Material = 6105-T6 Aluminum
- Est. Area = .438 Sq. In.
- Weight/ft = .515 lbs.
- 96", 192.63" Lengths standard.

Section Properties:

Moment of Intertia in⁴ .037
 Section modulus in³ .068

Load condition:
 Fixed at both ends, load at center
 Deflection = y (inches)

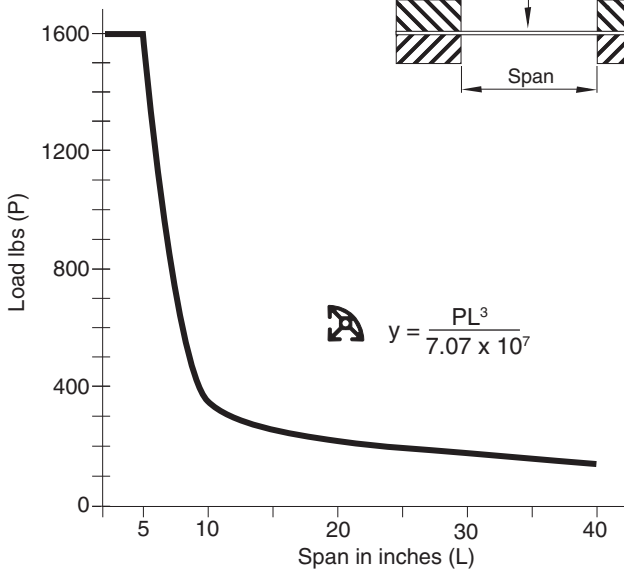
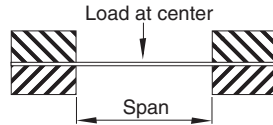

TECHNICAL

EX-14

Load condition:
Fixed at one end, sliding at one end,
load at center
Deflection = Y (inches)

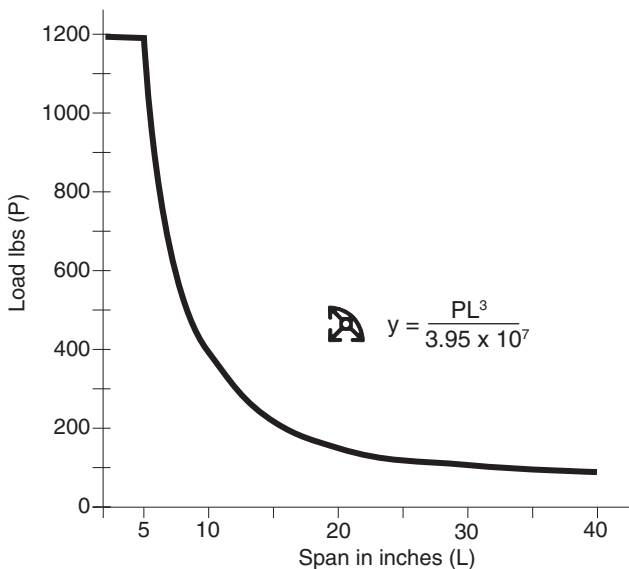
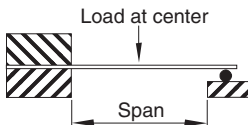

Load condition:
Fixed at one end,
load at unsupported end
Deflection = Y (inches)

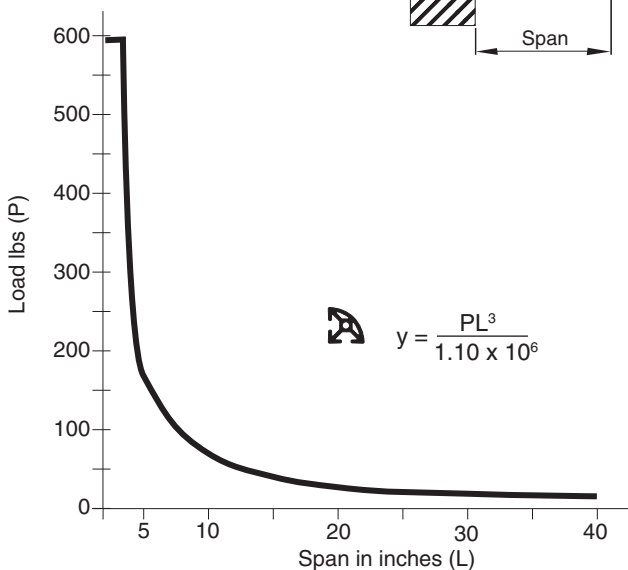
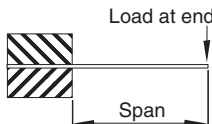

TECHNICAL