

EX-71

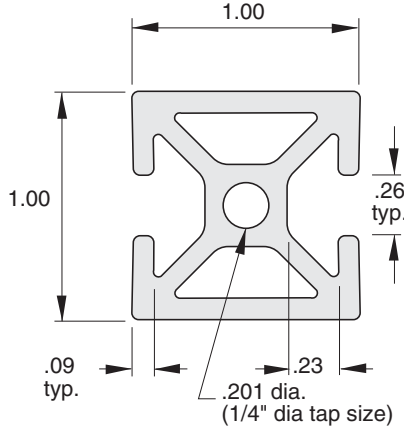

- Finish = Clear anodized
- Material = 6105-T5 Aluminum
- Est. Area = .451 Sq. In.
- Weight/ft = .550 lbs.
- 96", 192.63" Lengths standard.

Section Properties:

Moment of Intertia in ⁴	.057	.046
Section modulus in ³	.114	.093



Load condition:
Fixed at both ends, load at center
Deflection = y (inches)

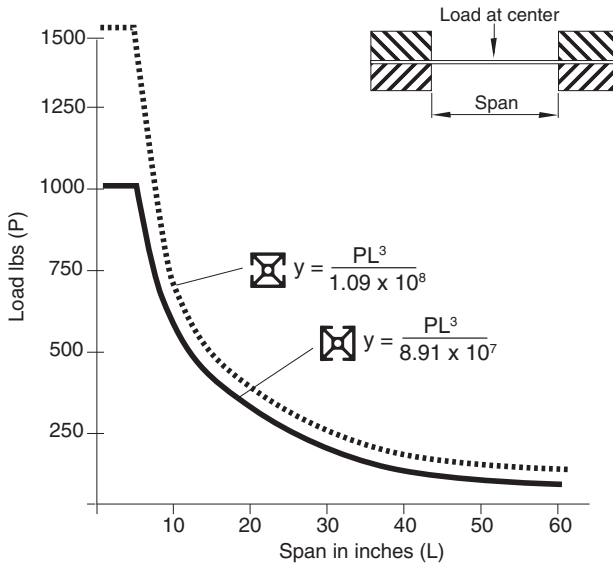

Load condition:
Fixed at one end, sliding at one end,
load at center
Deflection = Y (inches)

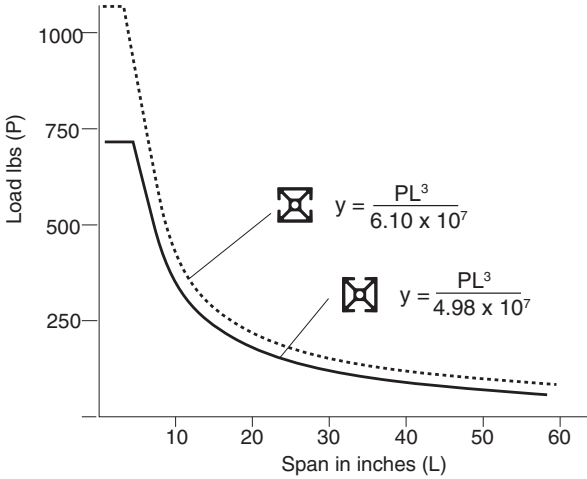
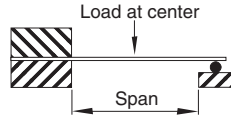

Load condition:
Fixed end at one end,
load at unsupported end
Deflection = Y (inches)

